



# **Ventilation Strategies for Bus Passenger Waiting Areas and Boarding Passages**

(Final Report)

By Prof. Jianlei Niu

Co-investigator: Yan Wu

Department of Building Services Engineering

July 2014

# Ventilation strategies for bus passenger waiting areas and boarding passages (Executive Summary)

Yan WU and Jianlei NIU  
Department of Building Services Engineering, PolyU

With the proposed green deck design, the tunnel exit will be extended further north, and so will the discharge of vehicle pollutants. The air pollutants levels on the deck will be much reduced and pedestrians will be free from direct exposure to the emission from tunnel vehicles. Also, a large open area of the green deck will induce high wind, in comparison with the existing street canyon situation on the road level. With relatively warm weather conditions in Hong Kong, the higher wind is desirable, leading to better thermal comfort. The current environment is a street canyon situation, with unfavorable wind and pollutant dispersions, and both the bus passengers and drivers are exposed to relatively high road-side pollutant concentrations. However, once covered by the green deck, it is expected that the semi-tunnel situation will be resulted in, and higher exposure level will be encountered if no special ventilation is provided. On the other hand, because of the favorable wind and air quality above the green deck region, new opportunities arise.

Bus waiting areas will be allocated to the mid-level, with semi-enclosed staircases leading to the open doors of the stopped buses downstairs on the ground level. The bus waiting areas will be provided with natural ventilation using wind catchers, which will pressurize the staircases to minimize pollutants migrated from the covered bus lanes. To assure the air quality and thermal comfort at low-wind conditions, mechanical ventilation will be provided in parallel. In addition, enclosed passageways are proposed to avoid high pollutant exposure of passengers and drivers during the boarding period.

The overall objective of the ventilation strategy is to prevent the vehicle emissions from escaping into the adjacent areas, and this will be realized via a holistic engineering approach by:

- a) Provision of a central mechanical exhaust with filtration;
- b) Use of wind catcher to utilize the favourable natural wind to pressurize the mid-level and the enclosed staircase and passage way.

In such a way, it is expected that the central mechanical extraction air volume will be designed to be the minimum required to maintain tunnel air pollutant level, yet better air quality in the passenger zone and the buses will be maintained by the clean air introduced from the wind catcher. The outcome is the reduced air pollutant exposure of bus passengers and drivers during the waiting and boarding, and reduced air-conditioning and ventilation fan energy use in the midlevel.

# **Ventilation strategies for bus passenger waiting areas and boarding passages**

Yan WU and Jianlei NIU

Department of Building Services Engineering, PolyU

## **1 Synopsis**

With the proposed green deck design, the tunnel exit will be extended further north, and so will the discharge of vehicle pollutants. The air pollutants levels on the deck will be much reduced and pedestrians will be free from direct exposure to the emission from tunnel vehicles. Also, a large open area of the green deck will induce high wind, in comparison with the existing street canyon situation on the road level. With relatively warm weather conditions in Hong Kong, the higher wind is desirable, leading to better thermal comfort.

The current environment is a street canyon situation, with unfavorable wind and pollutant dispersions, and both the bus passengers and drivers are exposed to relatively high road-side pollutant concentrations. However, once covered by the green deck, it is expected that the semi-tunnel situation will be resulted in, and higher exposure level will be encountered if on special ventilations are provided. On the other hand, because of the favorable wind and air quality above the green deck region, new opportunities arise.

Bus waiting areas will be allocated to the mid-level, with semi-enclosed staircases leading to the open doors of the stopped buses downstairs on the ground level. The bus waiting areas will be provided with natural ventilation using wind catchers, which will pressurize the staircases to minimize pollutants migrated from the covered bus lanes. To assure the air quality and thermal comfort at low-wind conditions, mechanical ventilation will be provided in parallel. In addition, enclosed passageways are proposed to avoid high pollutant exposure of passengers and drivers during the boarding period.

The overall objective of the ventilation strategy is to prevent the vehicle emissions from escaping into the adjacent areas, and this will be realized via a holistic engineering approach by: a) provision a central mechanical exhaust with filtration; b) use of wind catcher to utilize the favorable natural wind to pressurize the mid-level and the enclosed staircase and passage way. In such a way, it is expected that the central mechanical extraction air volume will be designed to be the minimum required to maintain tunnel air pollutant level, yet better air quality in the passenger zone and the buses will be maintained by the clean air introduced from the wind catcher. The outcome is the reduced air pollutant exposure of bus passengers and drivers during the waiting and boarding, and reduced air-conditioning and ventilation fan energy use in the mid-level.

## 2 Natural ventilation using wind catchers

The wind catcher is a traditional Persian architectural feature to catch higher speed wind for low rise and below ground level dwellings. Modern variations of the technology, with refined aerodynamic design have been found in UK (Wales) (see Fig. 1) and also in Hong Kong.



Fig. 1 Wind exhaust utilized in a building, Cardiff, Wales

The wind catcher design options were assessed. Effects of two factors, the wind catcher number and the wind catcher opening type (see Fig. 2), on the ventilation performance were investigated in two situations with enclosed staircases or open staircases between the mid-level and the ground level, respectively. Using the computational fluid dynamics (CFD) technique, the airflow patterns and pressure distributions were analyzed, and the air exchange rates were calculated. With the results of the current works, two ventilation strategies can be proposed.

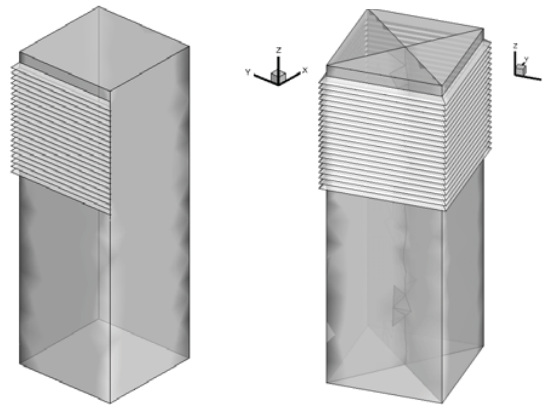

Fig. 2 Two different wind catcher opening types

## 2.1 Proposed ventilation strategies

### 2.1.1 Strategy 1

Enclosed staircases with doors leading to the ground floor where buses stop will be adopted. That is to say, the mid-level and the ground level can be ventilated separately.

For the ventilation of the waiting lobbies on the mid-level, natural ventilation will be employed. Two wind catchers connected to the roof the mid-level will be constructed. One wind catcher will be designed with an opening toward the upwind side and act as air supply, while the other one will have an opening facing the leeward side that act as the exhaust. The self-alignment of the wind catchers with the wind direction will be utilized to control its opening direction, which has been used in the building of Wales successfully (see Fig. 1). The airflow pathway in mid-level will be that fresh air flows in from one wind catcher, passes through the waiting areas and then flows out from the other wind catcher (see Fig. 3). A positive pressure will be created in the

waiting lobbies to refrain from the polluted air of the ground level while the doors of the staircases are open (see Fig. 4).

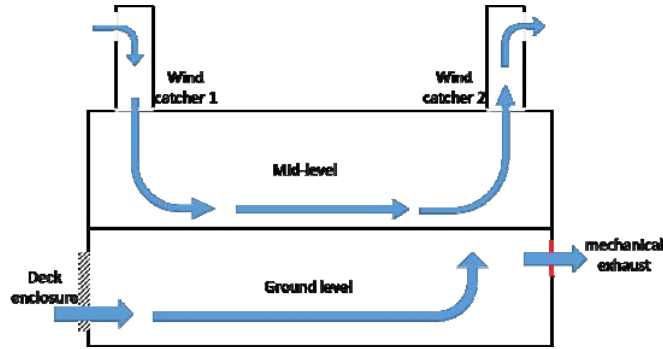
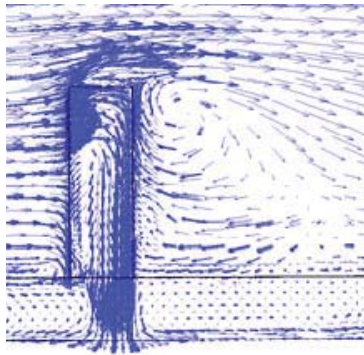
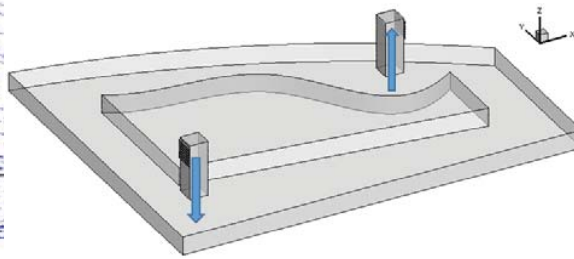

Fig. 3 Sketch map of airflow pathways in strategy 1



Airflow around the upward wind catcher



Airflow around the leeward wind catcher

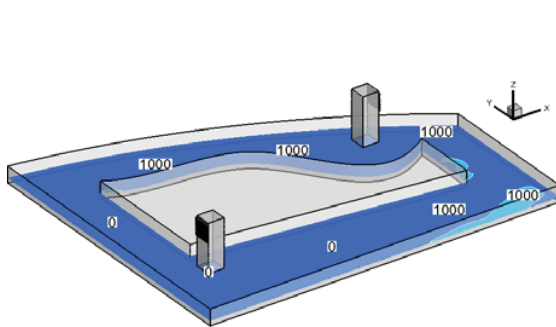

Simulated fresh air distribution

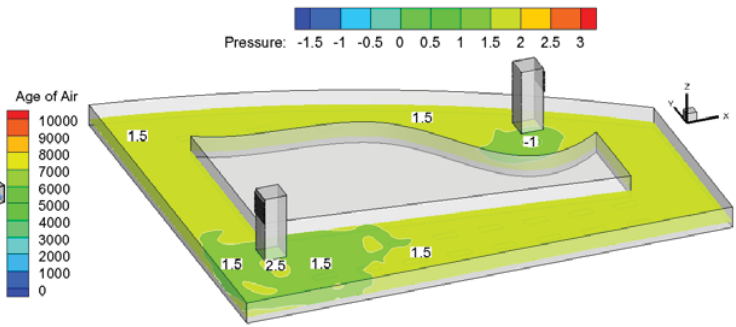

Simulated pressure distribution

Fig. 4 Simulated performance of wind catcher in Strategy 1

For the ventilation of the ground level, both natural ventilation and mechanical ventilation will be adopted. Air will be supplied naturally from the deck enclosure with ventilation louver walls,

and displaced and treated from the mechanical exhaust system and the filtration system (see Fig. 3). A negative pressure can be created in the ground level by the mechanical exhaust to avoid the polluted air expires out.

### 2.1.2 Strategy 2

Open staircases leading to bus stands on the ground level will be adopted, which means the mid-level and the ground level are connected. In this situation, the airflow through the staircases should be controlled from the mid-level to the ground level to protect passengers in waiting lobbies from the polluted air.

Natural ventilation will be employed for the air supply, while mechanical ventilation will be adopted for the exhaust. One wind catcher will be constructed on the roof of the mid-level with an opening toward the upwind side. Fresh air flows through the wind catcher into the mid-level, then passes through the open staircases to the ground level to remove the noxious gases exhausted by the cars together with the air from the deck enclosure. Finally, the air in the ground level will be discharged by the mechanical central exhaust system after the treatment of the filtration and purification system (see Fig. 5). A small positive pressure will be created in the mid-level and all airflows through the staircases are towards the ground level which avoids the escape of the vehicle emissions (see Fig.6).

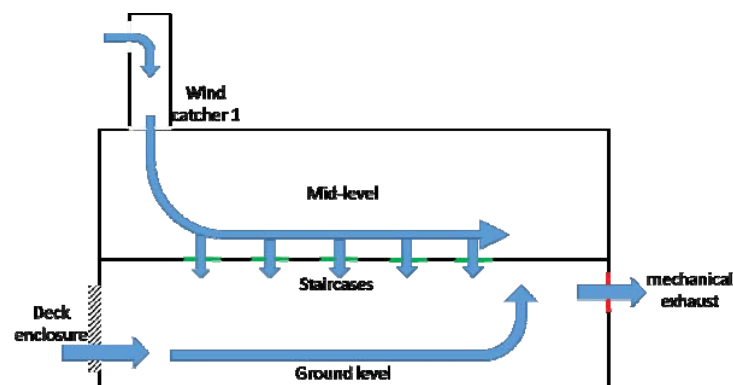

Fig. 5 Sketch map of airflow pathways in strategy 2

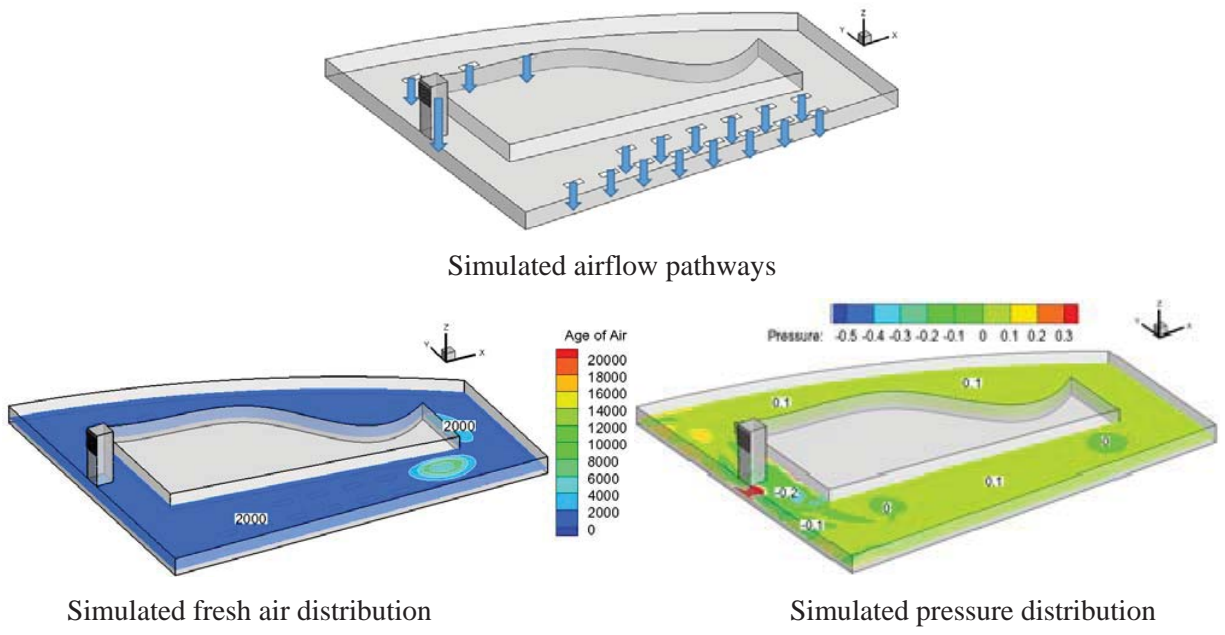

Fig. 6 Simulated performance of wind catcher in Strategy 2

## 2.2 Annual performance of wind catcher ventilation system

Annual performance of wind catcher ventilation system is analyzed based on the annual weather data. With the self-alignment of the wind catcher with the wind direction, the effect of the wind direction is neglected and only the effect of wind speed on the performance is considered. Fig. 7 shows the wind data of Hung Hom area from the Hong Kong planning department. Wind speeds between 2 to 12 m/s have highest probabilities.

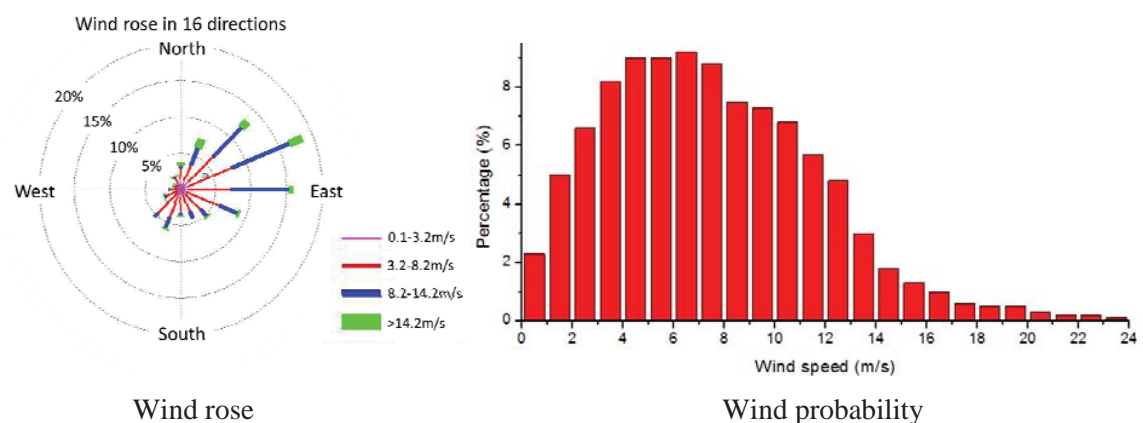

Fig. 7 Site wind data for Hung Hom



The performances of the wind catcher ventilation system in strategy 2 under the wind conditions with high probabilities were predicted. One wind catcher was constructed with the opening towards the windward side. The opening size of 5m×5m and the height of the opening bottom edge is 10m. The numerical calculated air exchange rates of the mid-level under different wind speed situations are presented in Fig. 8. It can be seen that the air change rate increases with the increase of the wind speed. And it is large enough even under low wind speed condition with present settings of wind catcher dimensions. That is to say, smaller wind catcher could have met the ventilation requirement. In addition, to match up with the landscape plan, one wind catcher could be divided into many smaller ones which have the same total air change rate with the big one. And a wind catcher with big head and small duct could also be proposed, which would further reduce the cover area of the wind catcher (see Fig. 9). And this optimal design would be considered in the detailed design stage, in consultation with architects.

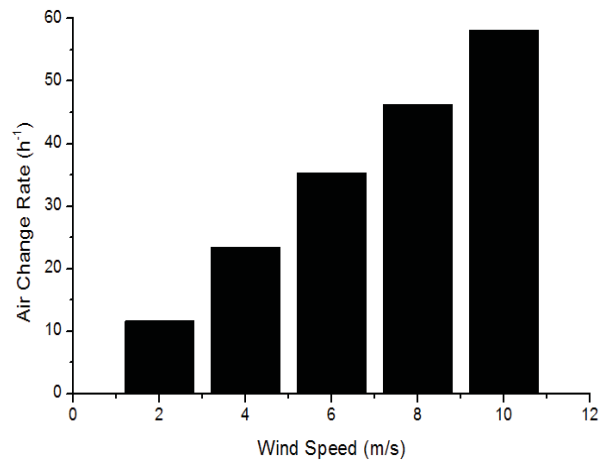

Fig. 8 Relationship between wind speed and air change rate of the mid-level

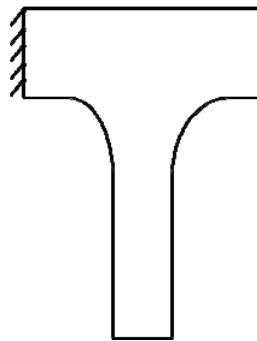

Fig.9 Optimized design of the wind catcher

### **3 Enclosed passageway to avoid high pollutant exposure of passengers and drivers**

In the semi-closed bus station of ground level, once bus doors are open after buses arrive, the vehicle exhaust would rush into the bus immediately and the exposure levels of passengers in the bus will be quite high, as well as boarding passengers. The passengers will be uncomfortable even when the bus stoppage time is not so long. Moreover, occupational health of bus drivers will suffer from the long term exposure in semi-tunnel environment with high pollutant concentrations.

An enclosed passageway connecting the bus waiting lobby and the bus is proposed to avoid the high exposure of passengers in ground level, which is similar to aircraft boarding bridge. The boarding bridge is a removable walkway connecting the gate of departure hall and an aircraft (see Fig. 10), which mainly includes a walking bridge and its column, a rotatable platform connecting the bridge and the departure gate, a pick mouth connecting the bridge and the cabin door as well as control and driving systems. Techniques of the boarding bridge have been mature with abundant of patents design and have been applied successfully. Using the proposed passageway with efficient control of its openings in enclosed or semi-closed bus stations, the exposure levels of passengers will be reduced significantly. Also, without the intruding of vehicles emission from ground level, the air quality in the bus waiting area of mid-level will be improved.



Fig. 10 Aircraft boarding bridge

### **3.1 Present techniques of the boarding bridge system**

#### 1) Automatic abutment technique

Automatic abutment system is employed to abut the pick mouth with the cabin door automatically, which includes image collection unit, pre-processing unit, database, visual recognition and positioning unit and boarding bridge motion control unit. After an aircraft parks near the boarding bridge, the system begins to work. The image information of the cabin door will be collected and pre-processed, and the relative location of the cabin door to the pick mouth will be calculated. Then, motion route information will be generated, which will control the pick mouth to move towards the cabin door and to complete the abutment process.

With this technique, the proposed passageway in bus stations can allow busses to stop in a small area near the passage but not just in a specific position.

#### 2) Pick up and awing devices

Pick up and awing devices are components of the pick mouth which connect the boarding bridge with the cabin. In these devices, combining flexible frames with rigid ones and applying aerated or buffered materials have been proposed, which could ensure the safety of the automatic abutment process.

#### 3) Wheel and lift devices of the walking bridge

Wheel and lift devices are installed on the columns under the walking bridge, which will allow the bridge to move in horizontal and vertical directions, respectively. With these devices, the passageway in bus station could adapt to different application situations.

#### 4) Other techniques

Innovate techniques about using transparent materials in the walking bridge and other structure improve designs could help to provide comfort environment for passengers. Mature techniques about the hydraulic control systems could also guarantee the automatic process.